

# PORTABLE *SCREW COMPRESSOR*

## CF190M-7 SERIES



**AIR PRESSURE: 7 bar**  
**FAD: 190 CFM / 5.4 m<sup>3</sup>/min**

### Main Improvements:

#### Availability for wide application

CFAIR model is line up to suit a wide range of applications such as pneumatic tools drilling and blasting.

#### Easy Starting in Cold Weather

This compressor is superior in cold weather starting.

#### Meters with Luminous Lights

Meters on operation panel are equipped with luminous light.

#### Reliable Warning Signal

Warning signals have luminiscent diode and so become more reliable.

#### Double Element Air Cleaner

Double element air cleaner prevents dust from entering when replacing element.

#### Easy Cleaning of Cooling System

This compressor is so designed that the interiors of radiator and oil cooler and also fuel tank can be easily and quickly cleaned.



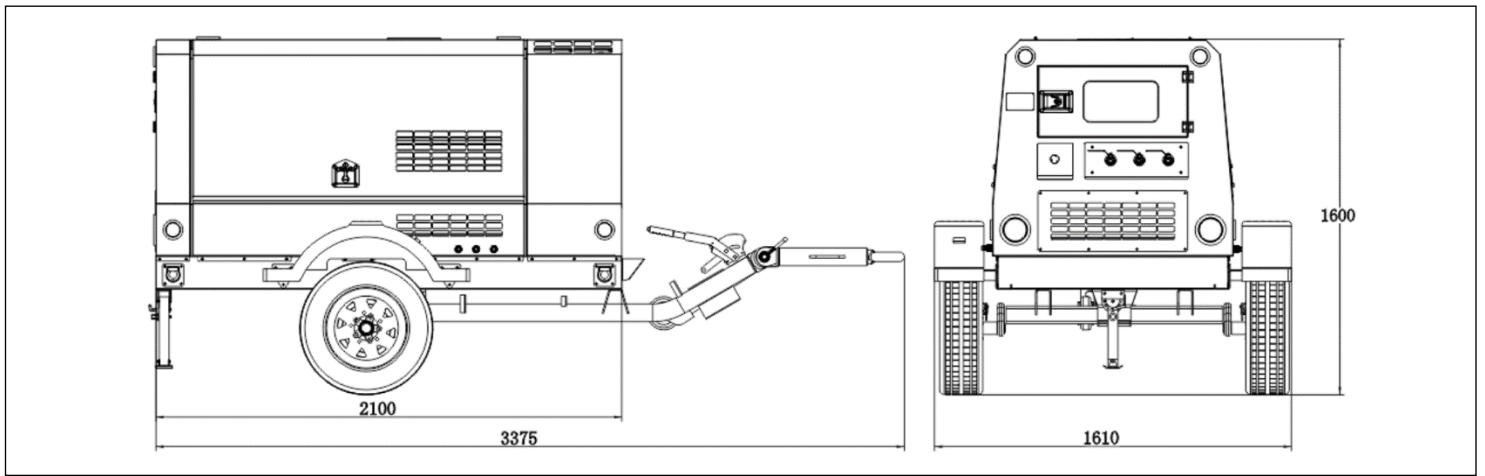

## COMPRESSOR

Type	Rotary twin screw, single stage, oil-cooled
Free air delivery	5.4 m <sup>3</sup> /min(190 cfm)
Working pressure	7 bar (101.5 psi)
Unloader	Suction port closing in connection with stepless speed regulator
Lubrication system	Forced lubrication by compression pressure
Driving system	Direct coupling with rubber
Oil cooling	Air-cooled
Air cleaner	Dry paper filter type

## OIL SEPARATOR-RECEIVER TANK

Type	Vertical, cylindrical, full-welded
Shell dia	250 mm
Shell length	784 mm
Capacity	32 L
Max. working pressure	1.58MPa
Hydraulic test pressure	2.37MPa
Air outlet valve	3pcs x 3 /4"
Recommend Oil type	#46

## DIESEL ENGINE

Model	ISUZU JX493G3
Type	Water-cooled, 4-cycle, Direct-Injection, Naturally aspirated
No. Of cylinders	4
Bore x stroke	93 mm x 102 mm
Total displacement	2.771 liters
Compression ratio	18.2 : 1
Rated output	44 kW( 59.8PS ) 2,500rpm
Max. torque	172 N.m/approx.2,000rpm
Governor	Mechanical
Alternator	DC 12 V, 35 A
Starting motor	DC 12 V, 2.2 kw
Battery	60AH X 1 pcs, 580CCA
Air cleaner	Two-stage dry type

## INSTRUMENTS & GAUGES

### EMERGENCY STOP DEVICES

Oil pressure switch
Engine coolant temperature switch
Discharge air temperature switch
Compressor oil temperature switch
Engine speed down switch

### GAUGES

Air Pressure gauge	Tachometer
Fuel level gauge	Engine oil pressure
Stop button	Engine coolant temp
Starter switch	Discharge air temp
Starting Loader	Discharge air pressure
	Hourmeter

## LIQUID CAPACITY

Fuel tank capacity	80 liters
Engine oil capacity	5 liters
Coolant capacity	8 liters
Compressor oil capacity	32 liters

## DIMENSIONS & WEIGHT

L x W x H	3375 x 1610 x 1600 mm
Weight	1120 Kg
20ft container	4 sets
40HQ container	16 sets



## MACHINERY GATE UNITED CO LTD.

Al Sulay - Riyadh, Kingdom of Saudi Arabia  
 TEL: +971 566 588 511 - +966 581 150 705  
 E-mail: info@machinerygate.com  
 http: www.machinerygate.com

### SAFETY

- Operate safely in accordance with proper operation manual.
- To prevent trouble and accidents, perform daily and preventive maintenance checks without fail.

